



PSB-36
PSB-42

Features

Dimensions:

PSB-36: 914L x 70W x 57H mm

PSB-42: 1067L x 70W x 57H mm

Material: Aluminum

Finish: Anodized Finish

Installation

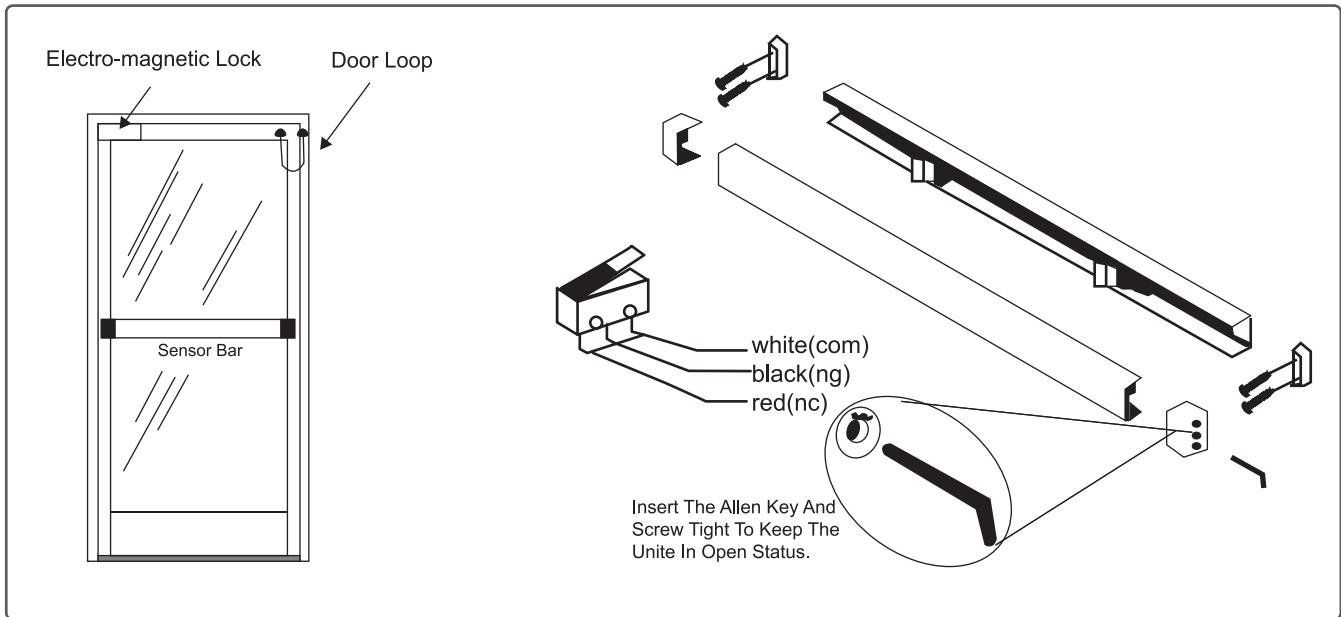

Wiring Diagram

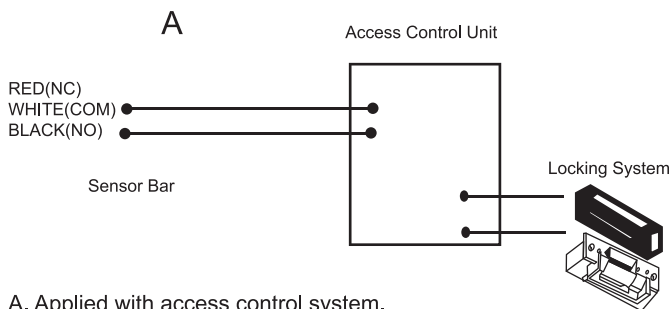

A. Applied with access control system.
Press the sensor bar to activate the access control unit to open.

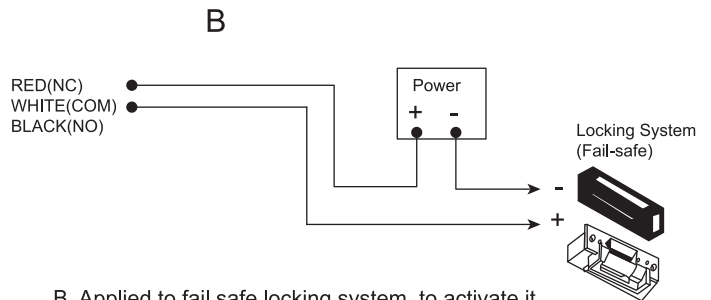

B. Applied to fail safe locking system, to activate it.
When applied to non-fail safe locking system,
connect to red wire (no).